

# ECDI - ECDC - ECDIM - ECDCIM - EICD - EICDC - ECDHL



ECDI series



ECDC series



ECDIM series



ECDCIM series



EICDHPT series



EICDC series



ECDHL series

EN

OPERATING MANUAL

CONDUCTIVITY PROBES

R2-07-18



This operating instructions contains safety information that if ignored can endanger life or result in serious injury.

Read these instructions **carefully** before use and keep them for future reference.

Information and specifications on this manual could be uncorrect or could have printing errors. Specifications are subject to change without notice.

---

### GENERAL SAFETY GUIDELINES

Operating, installing, or maintaining the unit in any way that is not covered in this manual could cause death, serious personal injury, or damage to the equipment.

#### SIMBOLI

This manual use the following safety message icon:



#### **Danger!**

Indicates a hazardous situation which, if not avoided, will result in death or serious injury.



#### **Warning!**

Indicates a hazardous situation which, if not avoided, could result in death or serious injury.



**Importante!** - Indica una situazione potenzialmente pericolosa che, se non viene evitata, può determinare un risultato o uno stato indesiderato. Una pratica non correlata a lesioni personali.



**Riferimento incrociato** - Questo simbolo indica un riferimento verso una pagina specifica o un paragrafo del manuale.







## PURPOSE OF USE AND SAFETY

### EQUIPMENT INTENDED FOR THE MEASUREMENT OF CONDUCTIVITY IN WATER.

Do not use in explosive area (EX).  
Do not use with flammable chemicals.  
Do not use with radioactive chemicals.

Use the probe in accordance with the data and specifications printed on the label.

Do not modify or use in a manner inconsistent with the provisions of the operating manual.

-  **When using this product with aggressive chemicals observe the regulations concerning the transport and storage of aggressive fluids.**
-  **When installing always observe national regulations.**
-  **Manufacturer is not liable for any unauthorized use or misuse of this product that may cause injury, damage to persons or materials.**
-  **Probes must be serviced and repaired by qualified and authorized personnel only.**
-  **Before any operation:**
  - always read chemical Material Safety Data Sheet (MSDS);
  - always wear protective clothing;
  - empty and rinse the liquid end before work on a the product which has been used with hazardous or unknown chemicals.
-  **Avoid grinding / shock / falls / friction.**

## Environmental safety

### Work area

Always keep the area clean to avoid and/or discover emissions.

### Recycling guidelines

Always recycle according to these guidelines:

1. If the unit or parts are accepted by an authorized recycling company, then follow local recycling laws and regulations.
2. If the unit or parts are not accepted by an authorized recycling company, then return them to the nearest representative.

### Waste and emissions regulations

Observe these safety regulations regarding waste and emissions:

- Dispose appropriately of all waste.
- Handle and dispose of the dosed chemical in compliance with applicable environmental regulations.
- Clean up all spills in accordance with safety and environmental procedures.
- Report all environmental emissions to the appropriate authorities.

## LABEL

Examples of labels.

Distributor

CODE: probe code

DESCRIPTION

N: quantity

P.N. (part number): serial number

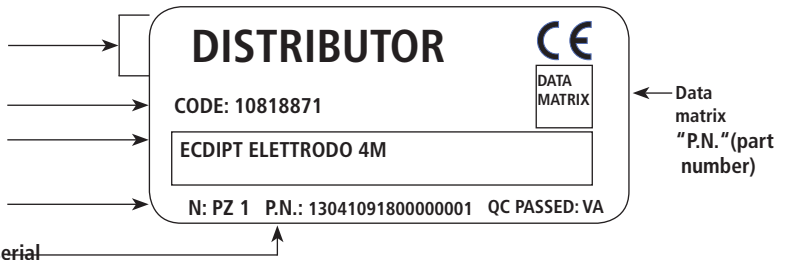

PROBE'S NAME

TECHNICAL DATA

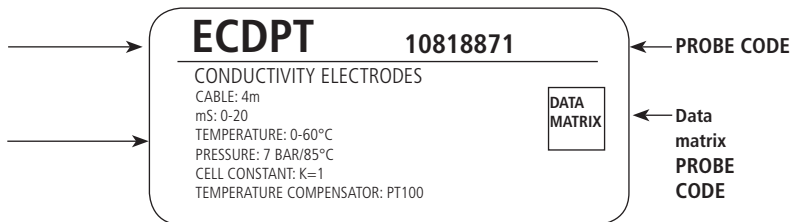

## Spare parts

For spare parts orders or any other communication, refer to the pump's label. Code (CODE) and serial number (P / N) uniquely identify the probe.

Transportation and storage

 A not suitable transportation or storage can cause damages.

Use original box to pack the probe.

Observe storage conditions also for transportation.

Although packed, always protect the unit against humidity and the action of chemicals.

 Before return the probe to the manufacturer Repair service, clean and rinse it.

 DO NOT TRASH PACKAGING. USE IT TO RETURN THE PROBE.

Transportation and storage temperature ..... 10 - 50°C (32 - 122°F)

Umidity..... 95% relative humidity (not condensed)

## MODELS

**ECDHL** Conductivity probes with platinum electrodes.  
High linearity

Fig. 1. ECDHL probe



### Technical features

Range:  
 ECDHL/01 ..... 0-200  $\mu$ S (K=0,1)  
 ECDHL/1 ..... 0,2-20 mS (K=1)  
 ECDHL/10 ..... 20-200 mS (K=10)

Temperature ..... 0-70° C (32-158°F)  
 Transportation and storage temperature 10-50°C (32-122°F)  
 Max pressure ..... 7 bar (101 PSI)  
 Cable lenght ..... 4,5 m  
 Material ..... Epoxy body; platinum electrode  
 Protection ..... IP65

ECDHL ..... not compensated  
 ECDHLC ..... Temperature NTC 10K compensated  
 ECDHLCPT ..... Temperature PT100 compensated

### Connection cable

COMPENSATION	CABLE		WIRES SIZE
/	RED	ELECTRODES	2 x 0.50
	BLACK		
	GROUND	GROUND	
NTC 10K	RED	ELECTRODES	2 x 0.50
	BLACK		
	GROUND	GROUND	2 x 0.50
	WHITE-GREEN	NTC 10K	
PT 100	RED	ELECTRODES	2 x 0.50
	BLACK		
	GROUND	GROUND	2 x 0.50
	WHITE-GREEN	PT 100	

## MODELS

### ECDC

Conductivity probes with graphite electrodes.

Fig. 2. ECDC probes



### Technical features

#### Range:

ECDC/1 .....	0-20 mS (K=1) - not compensated
ECDC/10 .....	0-200 mS (K=10) - not compensated
ECDCIM/1 .....	0-20 mS (K=1) - Temperature NTC 10K compensated
ECDCIM/10 .....	0-200 mS (K=10) - Temperature NTC 10K compensated
ECDCCPT/1 .....	0-20 mS (K=1) - Temperature PT100 compensated
ECDCCPT/10 .....	0-200 mS (K=10) - Temperature PT100 compensated

#### Immersion:

ECDCIM/1 .....	0-20 mS (K=1) - not compensated
ECDCIM/10 .....	0-200 mS (K=10) - not compensated
ECDCIMPT/1 .....	0-20 mS (K=1) - Temperature NTC 10K compensated
ECDCIMPT/10 .....	0-200 mS (K=10) - Temperature NTC 10K compensated
ECDCIPT/1 .....	0-20 mS (K=1) - Temperature PT100 compensated
ECDCIPT/10 .....	0-200 mS (K=10) - Temperature PT100 compensated

Temperature .....	0-60° C (32-158°F)
Transportation and storage temperature .....	10-50°C (32-122°F)
Max pressure .....	7 bar (101 PSI)
Cable lenght .....	4 m
Material .....	PVDF body; graphite electrode
Fitting .....	R3/4" (G1/2" immersion version)
Protection .....	IP65

**Connection cable**

COMPENSATION	CABLE		WIRES SIZE
N/A	RED	ELECTRODES	4 x 0.14
	BLACK		
	GROUND	GROUND	
NTC 10K	RED	ELECTRODES	4 x 0.14
	BLACK		
	WHITE	NTC 10K	
	GREEN		
PT 100	RED	ELECTRODES	2 x 0.50
	BLACK		
	BLUE	GROUND	4 x 0.22
	GREEN	PT 100	
	BROWN		
	YELLOW-WHITE		



## MODELS

### ECDI

Conductivity probes with stainless steel electrodes.

Fig. 3. ECDI



ECDI  
ECDIC  
ECDICPT

ECDIIM  
ECDICIM  
ECDICPTIM

### Technical features

Range:

ECDI/1 .....	0-5 mS (K=1) - not compensated
ECDI/01 .....	0-200 $\mu$ S (K=0,1) - not compensated
ECDIC/1 .....	0-5 mS (K=1) - Temperature NTC 10K compensated
ECDIC/01 .....	0-200 $\mu$ S (K=0,1) - Temperature NTC 10K compensated
dECDICPT/1 .....	0-5 mS (K=1) - Temperature PT100 compensated
ECDICPT/01 .....	0-200 $\mu$ S (K=0,1) - Temperature PT100 compensated

Immersion:

ECDI/1 .....	0-5 mS (K=1)
ECDI/01 .....	0-200 $\mu$ S (K=0,1)
ECDIC/1 .....	0-5 mS (K=1)
ECDIC/01 .....	0-200 $\mu$ S (K=0,1)
ECDICPT/1 .....	0-5 mS (K=1)
ECDICPT/01 .....	0-200 $\mu$ S (K=0,1)

Temperature..... 0-60° C (32-158°F)

Transportation and storage temperature 10-50°C (32-122°F)

Max pressure ..... 7 bar (101 PSI)

Cable lenght ..... 4 m

Material ..... PVDF body; stainless steel electrode

Protection ..... IP65

**Connection cable**

COMPENSATION	CABLE		WIRES SIZE
N/A	RED	ELECTRODES	4 x 0.14
	BLACK		
	GROUND	GROUND	
NTC 10K	RED	ELECTRODES	4 x 0.14
	BLACK		
	WHITE	NTC 10K	
	GREEN		
PT 100	RED	ELECTRODES	2 x 0.50
	BLACK		
	BLUE	GROUND	4 x 0.22
	GREEN	PT 100	
	BROWN		
	YELLOW-WHITE		

## MODELS

### EICDC

Stainless steel probes for conductivity.

Fig. 4. EICDC



### Technical features

Range:

EICDC/1 .....	0-20 mS (K=1) - Temperature NTC 10K compensated
EICDC/01 .....	0-200 $\mu$ S (K=0,1) - Temperature NTC 10K compensated
EICDC/001 .....	0-20 $\mu$ S (K=0,01) - Temperature NTC 10K compensated
EICDCPT/1 .....	0-20 mS (K=1) - Temperature PT100 compensated
EICDCPT/01 .....	0-200 $\mu$ S (K=0,1) - Temperature PT100 compensated
EICDCPT/001 .....	0-20 $\mu$ S (K=0,01) - Temperature PT100 compensated
EICDHPT/1 .....	0-20 mS (K=1) - Temperature PT100 compensated
EICDHPT/01 .....	0-200 $\mu$ S (K=0,1) - Temperature PT100 compensated
EICDHPT/001 .....	0-20 $\mu$ S (K=0,01) - Temperature PT100 compensated

Temperature..... 0-130° C (EICDHPT: 0-200°C)

Transportation and storage temperature 10-50°C (32-122°F)

Max pressure ..... 15 bar (218 PSI)

Cable lenght ..... 4 m

Material ..... stainless steel body; stainless steel electrode

Protection ..... IP65

**Connection cable**

COMPENSATION	CABLE		WIRES SIZE
NTC 10K	RED	ELECTRODES	4 x 0.14
	BLACK		
	WHITE	NTC 10K	
	GREEN		
	BLUE	SCHERMO	

PT 100	RED	ELECTRODES	4 x 0.22
	BLACK		
	GREEN	PT 100	
	BROWN		
	YELLOW-WHITE		
	BLUE	SHIELD	

**PROPER  
INSTALLATION**

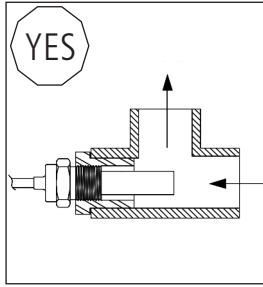

Sensor must be installed in such a way that flow is oriented towards the end of the probe.

This position avoids air bubbles and sediments on the probe that could alter readings.

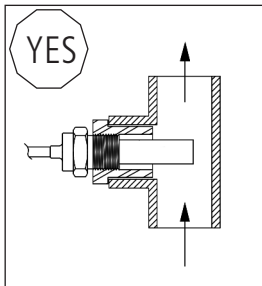

**INCORRECT  
INSTALLATION**

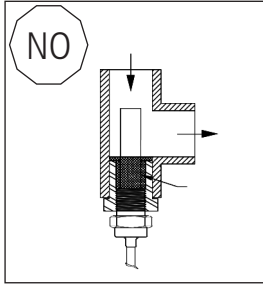

This installation could cause the deposit of impurities and solid parts.

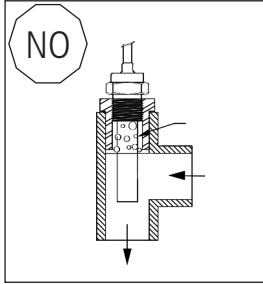

This installation could cause air bubbles around the probe

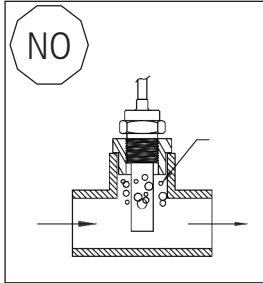

This installation could cause air bubbles around the probe

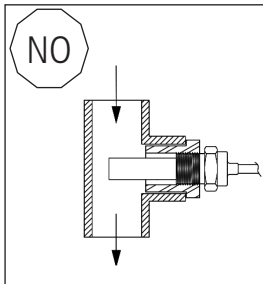

This installation could cause air bubbles around the probe or the deposit of impurities and solid parts.

**ASSEMBLING  
ECDHL**

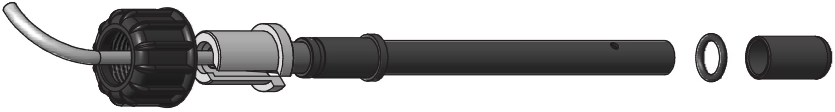

**INSTALLATION  
ECDHL**

- Install the probe in the probe holder as shown in the figure.

ECDHL / PEA



ECDHL / NPED



## CALIBRATION

Calibrate the probe monthly or more if the application need higher precision.

The sensor need to be calibrated to the instrument it is connected to.

Two points calibration: 0 and a value close to working point.

For better results:

- connect the probe to the instrument;
- calibrate at plant temperature.

### 0 Calibration

Wash and rinse the probe. Calibrate in air.

### 2nd point calibration

Use a buffer solution with a value close to working point. Completely dip the probe into the buffer solution.

**CAUTION:** Make sure that no bubbles are inside the cavity of the probe.

Perform calibration according to the procedure described in the instrument manual.



## MAINTENANCE

### Maintenance schedule

 In order to ensure the requirements of potable drinking water treated and the maintenance of the improvements as declared by the manufacturer, this equipment must be checked at least once a month.

#### OPERATOR PROTECTION

Use safety equipment according to the company regulations.

Use this safety equipment within the work area during installation, service and when handling chemicals:

- protective mask
- protective gloves
- safety goggles
- ear plugs or hear muffs
- further security device, if necessary.

#### POWER SUPPLY DISCONNECTION

Always disconnect power to the motor before you perform any installation or maintenance tasks. Failure to disconnect power will result in serious physical injury.

 Installation and maintenance tasks should be carried out by **AUTHORIZED AND QUALIFIED PERSONNEL** only in accordance with local regulations.

 Use original spare parts.

---

### Maintenance inspection

A routine maintenance includes a three-month inspections:  
Shorten the inspection intervals appropriately if the chemical is abrasive or corrosive.

#### Routine maintenance and inspections

Perform these tasks whenever you perform routine maintenance:

- Check probe integrity
- Check electrical wiring.
- Check for corrosion on parts of the probe
- Clean the probe.

---

### Probe cleaning

Regularly clean the probe to ensure a stable and accurate reading.

- Gently wash the probe with a detergent.
- Rinse with running water.
- Allow to immersion in a 5% HCl solution. Rinse with water.

#### ATTENTION!

DO NOT RUB ELECTRODE: ABRASIONS DAMAGE THE SURFACE AND CAUSE INCORRECT READING.

#### ATTENTION!

PLATINUM ELECTRODES **ECDHL SERIES**.  
DO NOT TOUCH THE PLATINUM SURFACE.  
PROBE COULD BE DAMAGED IRREPARABLY.

Dimensions

Fig. 5. Dimensions ECDHL (mm)

ECDHL/xx

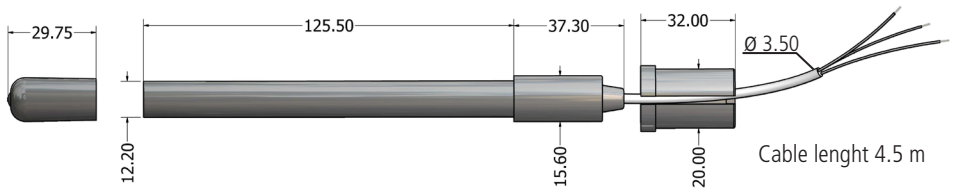

ECDHLC/xx

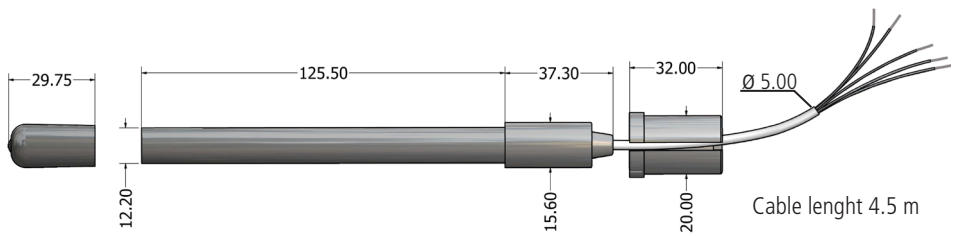

Dimensions

Fig. 6. Dimensions ECDC (mm)

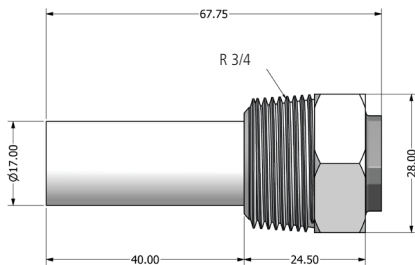

ECDC/K1  
ECDC/K1  
ECDCPT/K1

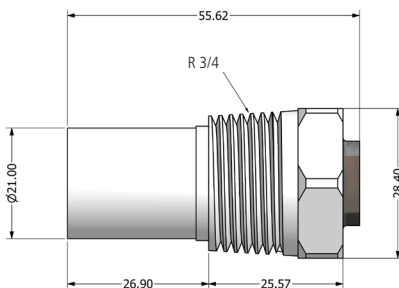

ECDC/K10  
ECDC/K10  
ECDCPT/K10

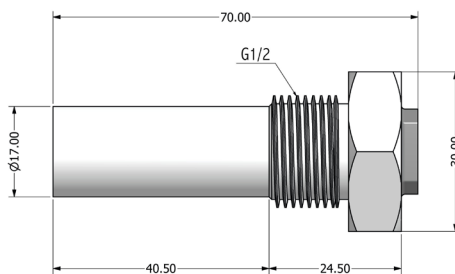
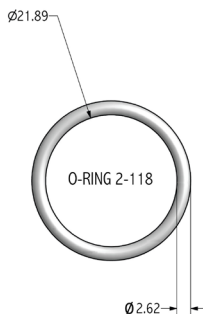

ECDCM/K1  
ECDCM/K1  
ECDCMPT/K1



Connector cable  
Length 4.0 m

Fig. 7. Dimensions EICDC (mm)

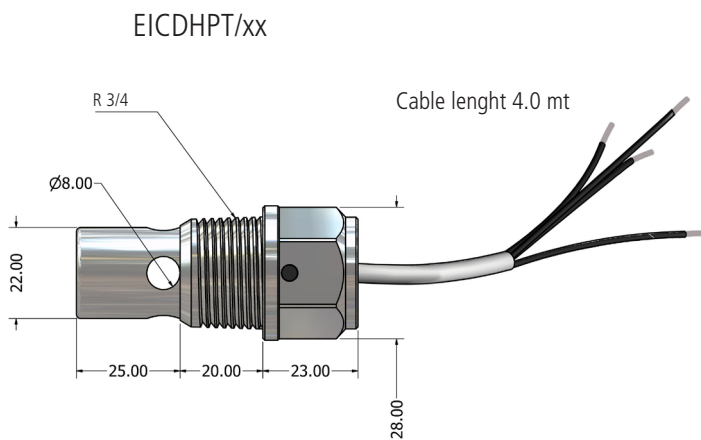
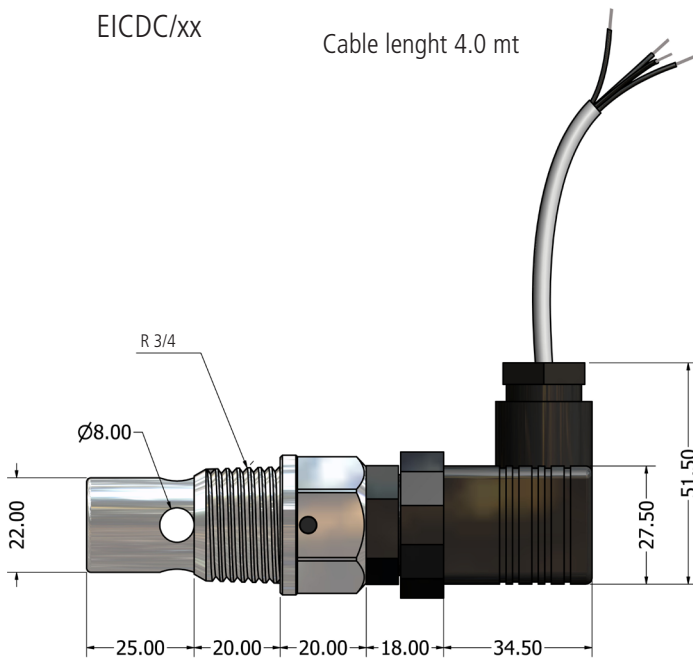

**Dimensions**

Fig. 8. Dimensions ECDI - ECDIC . ECDICPT (mm)  
3/4 K1 PVDF

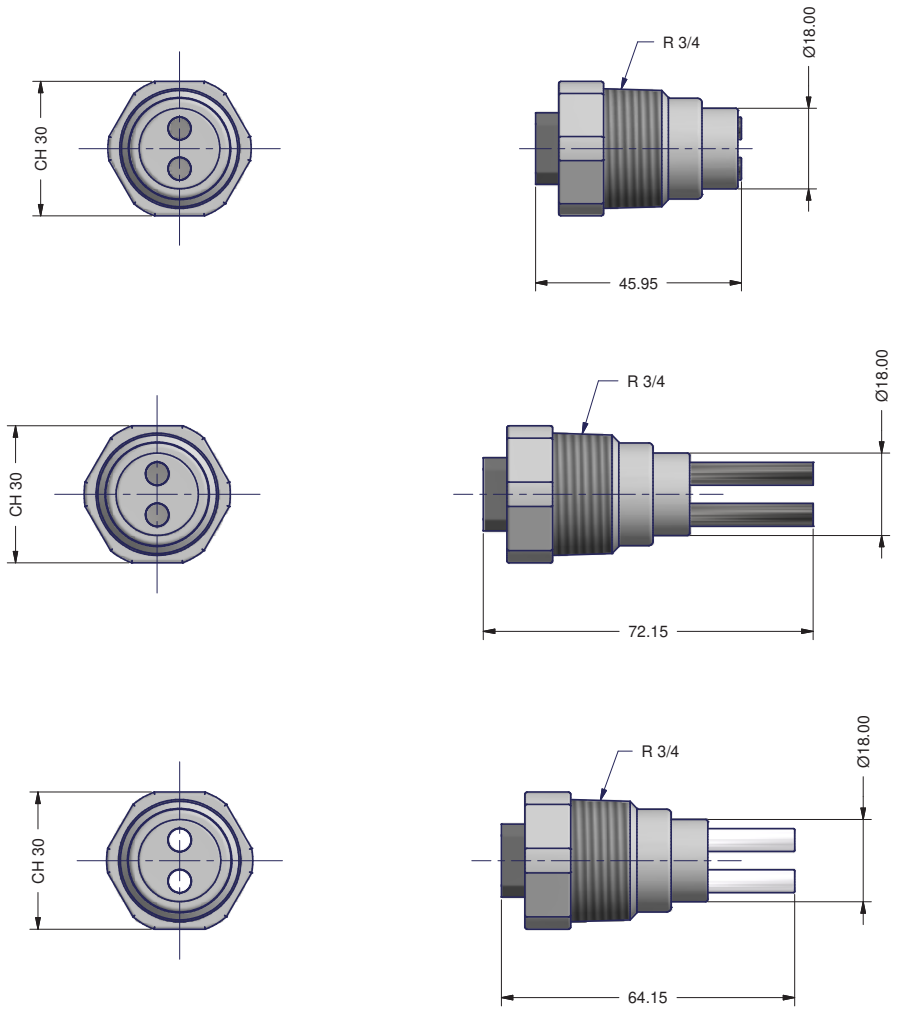

**Dimensions**

Fig. 9. Dimensions ECDI - ECDIC . ECDICPT (mm)  
3/8 K1 PVDF

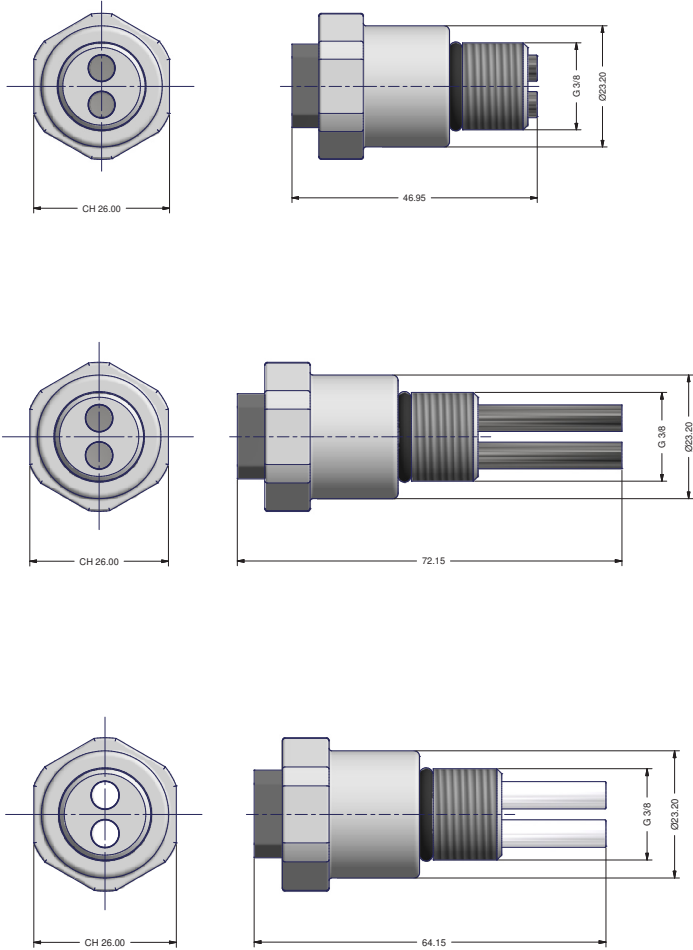

**Dimensions**

Fig. 10. Dimensions ECDI - ECDIC . ECDICPT (mm)  
1/2 K1 PVDF

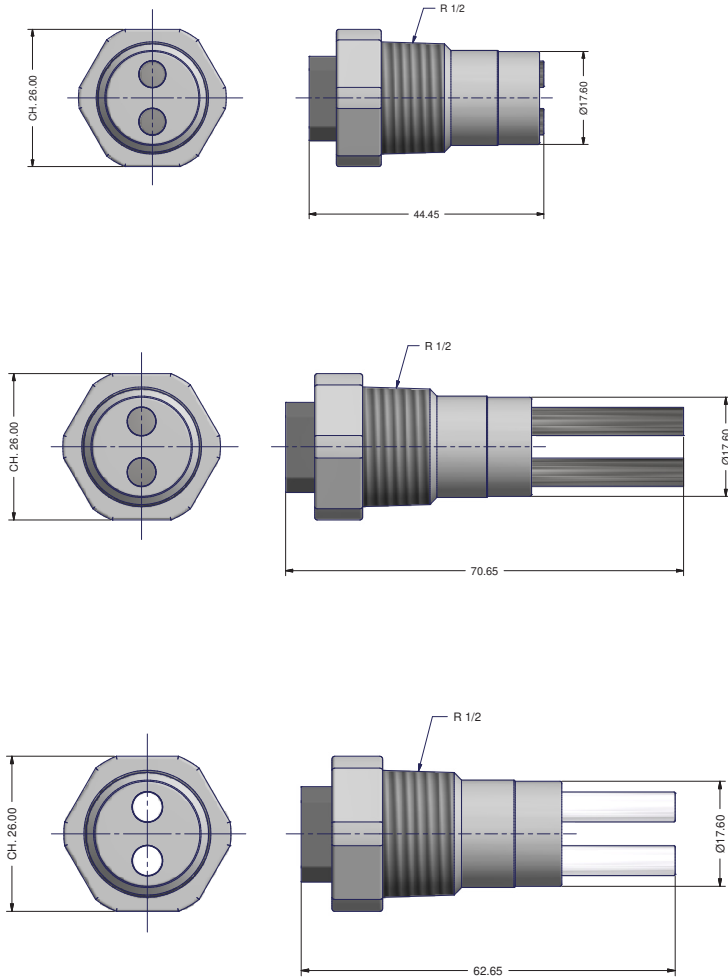

CONNECTOR  
CABLE

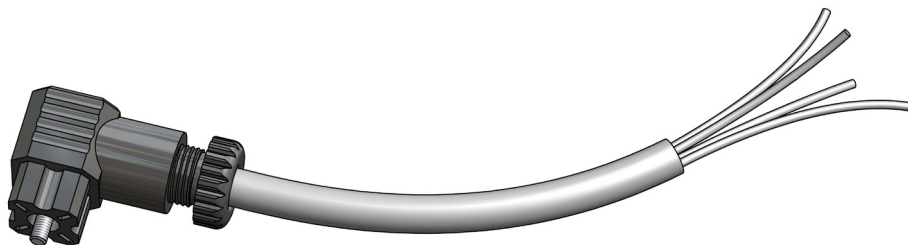

Connector cable

Length 4.0 m





**PRODUCT SERVICE REPAIR FORM**

ENCLOSE THE PRESENT FORM TO THE DELIVERY NOTE

DATE .....

**SENDER**

Company name.....  
Address .....

Phone no. ....

Contact person.....

**PRODUCT TYPE (see product label)**

DEVICE CODE .....

S/N (serial number).....

**OPERATING CONDITIONS**

Location/installation description .....

Chemical .....

Start-up (date) ..... Running time (approx. hours).....

REMOVE ALL THE LIQUID AND DRY IT BEFORE PACKAGING IN ITS ORIGINAL BOX.

**DESCRIPTION OF PROBLEM**

MECHANICAL  
Wear parts.....  
Brekage/other damages .....

ELECTRICAL  
Connections, connector, cables .....

NOT OR INADEQUATE FUNCTION/OTHER  
.....  
.....  
.....

**I declare that the product is free of any hazardous chemical.**

\_\_\_\_\_  
Signature of the compiler

\_\_\_\_\_  
Company stamp

## INDEX

<b>GENERAL SAFETY GUIDELINES</b> .....	2
<b>PURPOSE OF USE AND SAFETY</b> .....	3
<b>ENVIRONMENTAL SAFETY</b> .....	4
<b>LABEL</b> .....	4
<b>SPARE PARTS</b> .....	4
<b>MODELS</b> .....	6
ECDHL .....	6
Technical features.....	6
Connection cable .....	6
<b>MODELS</b> .....	7
ECDC .....	7
Technical features.....	7
Connection cable .....	8
<b>MODELS</b> .....	9
ECDI .....	9
Technical features.....	9
Connection cable .....	10
<b>MODELS</b> .....	11
EICDC .....	11
Technical features.....	11
Connection cable .....	12
<b>PROPER INSTALLATION</b> .....	13
<b>INCORRECT INSTALLATION</b> .....	14
<b>ASSEMBLING ECDHL</b> .....	15
<b>INSTALLATION ECDHL</b> .....	15
<b>CALIBRATION</b> .....	16
<b>MAINTENANCE</b> .....	17
Maintenance schedule.....	17
Maintenance inspection .....	17
Probe cleaning .....	17
Dimensions .....	18
Probe Service Form.....	26



Tutti i materiali utilizzati per la costruzione della pompa dosatrice e per questo manuale possono essere riciclati e favorire così il mantenimento delle incalcolabili risorse ambientali del nostro Pianeta. Non disperdere materiali dannosi nell'ambiente! Informatevi presso l'autorità competente sui programmi di riciclaggio per la vostra zona d'appartenenza!